

PIPE/CONDUIT CLAMPS

FOR 1 5/8" (41 MM) WIDTH SERIES CHANNEL



1 5/8" Channels

Nuts & Hardware

General Fittings

Pipe/Conduit Supports

Electrical Fittings

Concrete Inserts

1 1/4" Framing System

1 3/16" Framing System

Spec. Metals & Fiberglass

Index

P2558-5 thru P2558-60

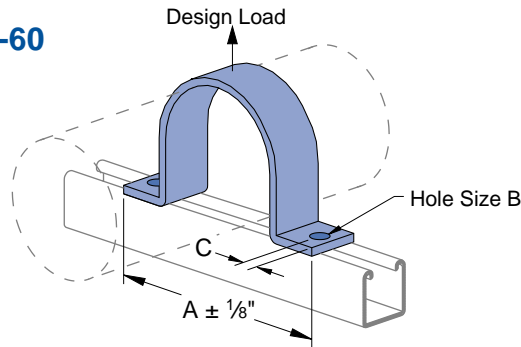

SINGLE PIECE PIPE STRAP

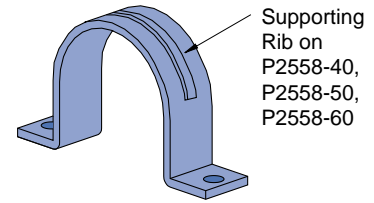

Hardware sold separately.

Part Number	Nominal Pipe Size	"A"		"B"		"C"		Thickness In (mm)	Weight/C		Design Load Lbs (kN)
		In	mm	In	mm	In	mm		Lbs	kg	
P2558-05	1/2	27/8	73.0					1/8" (3.2)	23	10.4	500 (2.2)
P2558-07	3/4	3 1/8	79.4						26	11.8	
P2558-10	1	3 3/8	85.7	9/32	7.1	7/16	11.1		31	14.1	
P2558-12	1 1/4	3 3/4	95.3						35	15.9	
P2558-15	1 1/2	3 7/8	98.4						39	17.7	
P2558-20	2	5 3/4	146.1					1/4" (6.4)	94	42.6	1000 (4.4)
P2558-25	2 1/2	6 1/4	158.8						114	51.7	
P2558-30	3	6 7/8	174.6						133	60.3	
P2558-35	3 1/2	7 3/8	187.3	7/16	11.1	1 1/16	17.5		152	68.9	
P2558-40	4	7 7/8	200.0						176	79.8	
P2558-50	5	9	228.6						198	89.8	
P2558-60	6	10	254.0						225	102.1	

P2609 thru P2617 P2426 thru P2431

UNI-CLIP SUPPORT

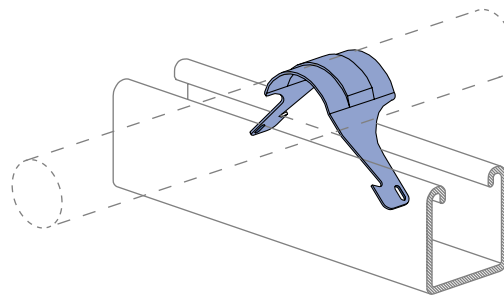

The Uni-Clip supports exceed load requirements for American Standard Code for Pressure Piping (1967), and National Electric Code (1971). Patent No. 2863625.

Material: Stainless steel type 301.

UNI-CLIP SUPPORTS FOR RIGID STEEL CONDUIT

Part Number	Conduit Size		O.D. Size		Weight/C	
	In	mm	In	mm	Lbs	kg
P2609	3/8	.675	17.1	1.6	0.7	
P2611	1/2	.840	21.3	2.3	1.0	
P2612	3/4	1.050	26.7	3.2	1.5	
P2613	1	1.315	33.4	4.1	1.9	
P2614	1 1/4	1.660	42.2	5.1	2.3	
P2615	1 1/2	1.900	48.3	6.3	2.9	
P2617	2	2.375	60.3	10.0	4.5	

UNI-CLIP SUPPORTS FOR THINWALL CONDUIT (E.M.T.)

Part Number	Conduit Size		O.D. Size		Weight/C	
	In	mm	In	mm	Lbs	kg
P2426	1/2	.706	17.9	1.7	0.8	
P2427	3/4	.922	23.4	2.4	1.1	
P2428	1	1.163	29.5	3.6	1.6	
P2429	1 1/4	1.510	38.4	4.6	2.1	
P2430	1 1/2	1.740	44.2	5.9	2.7	
P2431	2	2.197	55.8	8.0	3.6	

PIPE/CONDUIT CLAMPS, SUPPORTS AND HANGERS

FOR 1 5/8" (41 MM) WIDTH SERIES CHANNEL



1 5/8" Channels

Nuts & Hardware

General Fittings

Pipe/Conduit Supports

Electrical Fittings

Concrete Inserts

1 1/4" Framing System

3/16" Framing System

Spec. Metals & Fiberglass

Index

Page

Pipe/Conduit Clamps

129

Pipe Hangers

139

Pipe Rollers

140

Pipe Brackets

143

Reference Tables

144



MATERIAL

Unistrut pipe supports, unless noted, are punch-press made from hot-rolled, pickled and oiled steel plates, strip or coil, and conform to ASTM specifications A366, A575, A576, A635, or A36. The fitting steel also meets the physical requirements of ASTM A570 GR 33. The pickling of the steel produces a smooth surface free from scale.

Many items are also available in stainless steel. Consult factory for ordering information.

FINISHES

Pipe supports are available in: electro-galvanized (EG), conforming to ASTM B633 Type III SC1; Hot-

dipped galvanized (HG), conforming to ASTM A123 or A153; Perma-Green II (GR), and plain (PL).

APPLICATION

Unistrut pipe clamps, pipe hangers, brackets and rollers are designed for the support of electrical and mechanical services. Supports to meet nearly every requirement can be attained using Unistrut Metal Framing components.

DIMENSIONS

Imperial dimensions are illustrated in inches. Metric dimensions are shown in parenthesis or as noted. Unless noted, all metric dimensions are in millimeters and rounded to one decimal place.

DESIGN BOLT TORQUE

BOLT SIZE	1/4"	5/16"	3/8"	1/2"	5/8"	3/4"
FOOT LBS.	6	11	19	50	100	125
N·m	8	15	25	70	135	170

Note: When tightening 1/4" screws used with a two piece pipe clamp, a torque of 5 foot pounds (60 inch-pounds) should be used.

DESIGN LOAD

Design load data, where shown, is based on the ultimate strength of the connection with a safety factor of 5.0, unless otherwise noted.

Perma-Green® III (GR)

Technical Data:

STEEL SUBSTRATE PREPARATION

Ten stage continuous cleaning, phosphate process. Substrate after "prep": sealed zinc phosphate conversion coating.

COATING

Thermostat acrylic
Color: FHWA Highway Green
Color Tolerance Chart PR Color No. 4
Hardness: 2H.
Coating Process: Cathodic Electrodeposition.

PERFORMANCE

Salt Spray:
Scribed: exceeds 400 hours per ASTM B117. (1/8" creep)
Unscribed: exceeds 600 hours per ASTM B117. (6% red rust)
Chalk: Nominal at 1,000 hours per weatherometer G-23 test.
Checking: None at 1,000 hours per weatherometer G-23 test.
Fade: Less than 50% compared to standard epoxy E.C. coatings.

ENVIRONMENTAL ISSUES

Formulated as a "heavy metal"-free coating (trace elements only).
Outgassing in service: essentially none at 350°F for 24 hours.

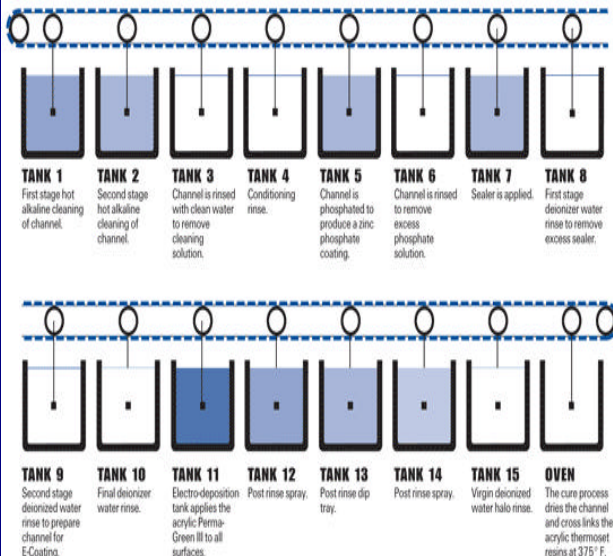

The performance of Unistrut's Perma-Green III far exceeds that of conventional finishes. And compared to competitive "high-performance" coatings, Perma-Green III provides superior resistance to chalking, checking and fading and is far less vulnerable to common acidic atmospheres, solvents and alkalis. Just as important, Perma-Green III is the result of an environmentally neutral process that virtually eliminates the toxic metals commonly found in competitive paint-based finishes.

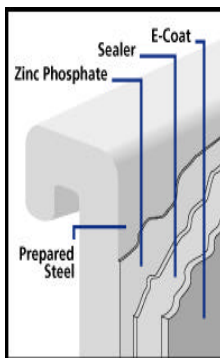

Unistrut Perma-Green III is a factory applied, electro-deposition acrylic coating with superior rust protection and fade-resistance. The acrylic coating is a proprietary formulation and is essentially "heavy-metal" free. The electrodeposition coating process provides a smooth, hard, durable surface which is completely cured. This inhibits introduction of airborne contaminants which can adversely affect sensitive manufacturing environments.

Before the electrodeposition acrylic coating is applied, Unistrut channel is thoroughly cleaned and coated with a zinc phosphate conversion coating. Unistrut's unique, custom-designed "prep" process consists of ten separate steps, the most thorough in the industry. The cleaning, phosphating and electrodeposition coating processes are continuous and, unlike "batch" processing, result in a uniform quality coating.

Production samples are tested on a continuous basis for corrosion resistance. Unistrut Perma-Green III exceeds 400 hours salt spray (1/8" creep from scribe) when tested to ASTM B117. Unscribed samples exceed 600 hours salt spray. (6% red rust)